

## Dual axis Inclinometer / Accelerometer Sensor KAS202-57A and KAS202-58A

- 4 ... 20mA (3-wire) current output
- high repeatability up to 2mg/0,01% over range
- high resolution up <math><1\text{mg}/0,005\text{\%}</math>
- Dual axis versions for acceleration measuring
- Inclination sensors are temperature compensated
- Sensor is calibrated at  $0^\circ / 1\text{g}$
- Sensor element shock proof  $\geq 20.000\text{g}$
- Operation temperature range  $-40 \dots +85^\circ\text{C}$
- Rugged water proof metal housing
- Rugged M12 connector (IP67/68 with closed cap)
- Three wire interface, reverse polarity protected

### Options/other versions:

- High resolution measuring ranges:  
 $0,005\text{mA} = 0,001^\circ$
- $\pm 30 \dots 90^\circ$  dual axis versions
- $\pm 2 \dots 18\text{g}$  dual axis versions
- Two wire (current loop) versions
- IP68/69 Cable-Version available
- Digital output with  $\pm 15 \dots 180^\circ$  range
- Customized adaptations in small quantities

The sensing elements work based on the capacitive principle. They feature high precision and high shock resistance, resulting among others from the improved **bulk** micro electro mechanical system, made of high purity silicon. Due to the especially appropriate structure, no drifts caused by deformation of the sensing mass are expected even after severe hits. The gas damping inside the sensing element prevents resonance oscillations or overshooting of the sensing mass.

The sensor is mounted in a water proof housing (IP67/68) which provides three holes for fixation and a commonly used M12 connector (IP67/68). The 4 ... 20mA output allows for long connecting lines. Using an appropriate resistor, the current output can be converted to a 1 ... 5V or 2 ... 10V voltage signal.

This sensors are available in dual axis versions with  $\pm 30 \dots \pm 90^\circ$  (KAS201-Serie),  $\pm 1,5 \dots 8^\circ$  (KAS211-Serie),  $\pm 2 \dots 4\text{g}$  (KAS202-Serie) and  $\pm 6 \dots 18\text{g}$  (KAS203-Serie) measuring ranges.

All sensors are calibrated at  $1\text{g}/0^\circ$ . Thus a further zero alignment (other than mechanical adjustment to the application) is not necessary.

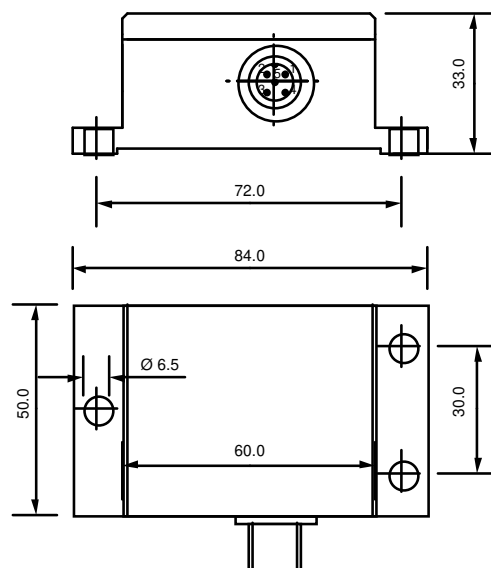

## Specifications

Parameter	Condition	KAS202-57A	KAS202-58A	Unit
Measuring range <sup>4)</sup>		+/- 2	+/- 4	g °
Repeatability at 0° (horizontal position) <sup>1)</sup>	20°C typically	2 (0,2)	<4	mg °
Resolution at 0° / 1g	DC .. 1Hz typically	0,08	<2	mg °
typ. Offset temperature dependency <sup>7)</sup>	20..60°C	ca. 0,5	ca. 1,1	mg / °C ° / °C
long term stability <sup>6)</sup>	10 years <sup>6)</sup>	ca. +/- 2 <sup>7)</sup>	ca. +/- 4 <sup>7)</sup>	mg °
Measuring direction	axis	X / Y		
Cross axis sensitivity <sup>2)</sup>	max / typ	4/1		%
Damping	-3 dB	50 <sup>5)</sup>	115 <sup>5)</sup>	Hz
Operating temperature range	not condensing	-40 .. +85		°C
Shock resistance Chip <sup>7)</sup>	min	20'000		g
Output signal I <sub>out</sub>		4 .. 20		mA
Output signal I <sub>out</sub> 0°-position		12		mA
Sensitivity	nominal <sup>4)</sup>	(0.07)	(0.035)	mA/°
	nominal	4	2	mA/g
Power supply <sup>3)</sup>	stabilized	20 .. 30		VDC
Connection		M12male		
Water resistance <sup>8)</sup>		IP67/68/69 <sup>8)</sup>		IP-class

- 1) **Repeatability:** maximum offset occurring with position change after return to initial position (corresponds to achievable precision, including temperature hysteresis after temperature compensation and linearization).
- 2) **Cross axis sensitivity:** maximum error occurring with (additional) inclination or acceleration from another direction than the measuring plane
- 3) **Supply** stabilized
- 4) **Measuring range:** Trigonometric function

$$\text{angle} = \arcsin\left(\frac{I_{\text{out}} - 12 (\text{Offset})}{\text{Sensitivity}}\right)$$

(values without units)

- 5) Typical values
- 6) **Long term stability:** calculated values from HTB tests. Test results available at request.
- 7) Related to sensing element
- 8) IP69 : cable with cable clamp instead of connector

**More detailed connection instruction please sees in the files “applications basics” and “user guide”**

a.b.jödden gmbh  
Europark Fichtenhain A 13a  
47807 Krefeld, Germany

Phone +49 2151 516259 0  
Fax +49 2151 516259 20

info@abjoedden.de  
www.abjoedden.de